

LA21A

МУЗЦЕНТР
МУЗЫКАЛЬНОЕ ОБОРУДОВАНИЕ

<https://muzcentre.ru>

Presentation:

Compact vertical line array element designed to provide high performance, detailed highs and a well-defined midrange.

The LA21A has built-in premium quality EU transducers (2x 10" - 2.56in VC) and 1x 1.4" - 2.56in VC Neodymium HF driver, both combinations ensuring powerful and crystal clear reproduction, high SPL with an extended frequency response. The MF/HF pattern control is array splay dependent and horizontal coverage is 100° thanks to true wave guide horn that ensure consistent and long range projection with very low distortion levels.

As self-powered system, the LA21A incorporates a 2-channel Class D amplifier and a DSP for real time operation according to different environments and music styles. With 4 user-defined presets than can be selected on the rear panel, the class D amplifier is prepared for 85-264Vac global mains voltage (SMPS with PFC) and features various electronic protections to guarantee the use of the speaker system in perfect sound and safe operation.

LA21A rugged enclosure is manufactured using 15/18mm birch plywood painted in hard-wearing and durable polyurea coating, equipped with fully integrated rigging hardware with quick-release bolts/pins to ensure fast and easy setup, designed for flying and ground stacking applications.

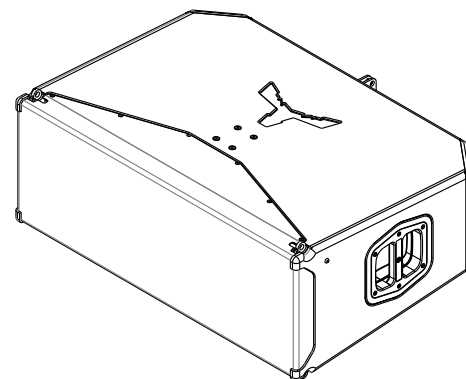

Features:

- 2-way Curvilinear array element
- Trapezoidal enclosure
- 2x 10" (2.56in VC) MF (front loaded) EU transducer
- 1x 1.4" (2.56in VC) Neodymium EU driver
- 2-channel Class D amplifier with integrated DSP
- Universal 85-264Vac mains, SMPS with PFC
- Passive or biamp operation (user-selectable)
- Integrated rigging flyware, stacked and flown configurations
- Rugged and durable 15mm birch plywood construction
- Powder coated custom perforated steel grille

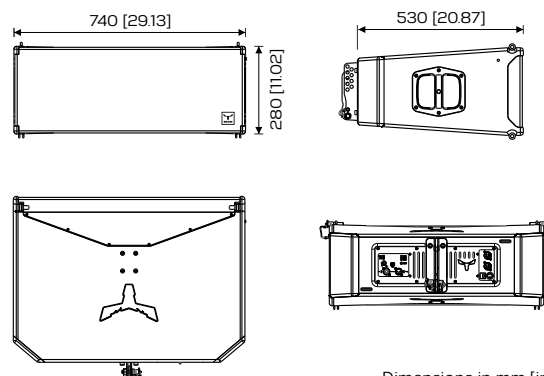

Dimensions in mm [in]

Technical specifications:

Acoustical

Type	2-way Curvilinear array element
Enclosure design	Trapezoidal array enclosure
Power rating (RMS/Peak)	700W / 2800W
Frequency range	52 - 19.5kHz (-10dB)
Nominal impedance	N/A
Transducer type	2x 8" LF (2in VC) EU transducer, front loaded 1x 1.4" HF NEO (2.56in VC) EU transducer
Dispersion	100°x array length-splay dependent (HxV)
Crossover frequency	N/A
SPL (1W/1kHz)	135dB @ 1m

Mechanical

Enclosure	15mm birch plywood, rugged polyurea coating
Grille	Custom perforated metal grilles w/ acoustic foam
Color	Black or white textured
Hardware	Integrated steel rigging flyware Splay angle adjustment, 8° (1° increments) Ø9.8mm ball pins w/ stainless steel lanyard with PVC
Dimensions	740x530x280mm 29.13x20.87x11.02in
Weight	32Kg 70.55lb

Amplifier Module

Type	2-channel Class D
Output Power	800W + 400W (continuous)
Internal Processing	Fully programmable DSP 48KHz sampling frequency 24 bit AD/DA converter
Audio input/output	XLR/Jack combo connector XLR/M 3p
Indicators	Power, signal/preset, status, clip
Controls	Master level control, 4 selectable presets
AC Mains	SMPS with PFC, 85-264Vac universal mains
AC Mains connector	Neutrik® powerCON, Power-in/Power-out
Protections	Over current, short circuit, thermal, DC and HF